

Single Speed Windshield Wiper Motor

- Drives up to 16" / 400mm arms and blades
- Available in pre-set sweep angles of 100, 120, 140 or 160 degrees
- Internal thermostwitch protection
- RFI suppression
- Durability tested to SAE J198C, 1.5 million cycles
- Optional covers available in white or black, with or without switch cut outs
- Optional mounting hardware kits



Recommended for

- Thru-the-glass installations
- ATV / UTV
- Side by side
- Marine
- Material handling vehicles
- Skid steer
- Rear window applications

MOTOR TORQUE: 9Nm

VOLTAGE: 12v, available in 24v upon request

AMPERAGE: 1A (no load), 10A (Stall)

SPEED: 43 +/- 5 sweeps per minute

PARK CIRCUITRY: coast-to-park

WEIGHT: 2.4 pounds / 1.1 kilograms

GROUNDING: isolated, white wire

SHAFT: 10 x 8 DIN, stainless steel, 1" length mounts thru-glass. 2" shaft for panel mount applications upon request

GROUNDING: chassis ground

WIRING: 18 AWG, 8" / 200mm lead

FUSING: 12A for 12v / 7A for 24v

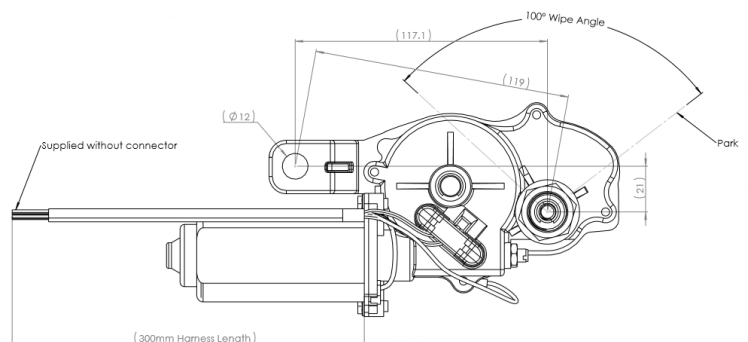

www.wexcoind.com

customerservice@wexcoind.com

WEXCO Industries
3 Barnet Road
Pine Brook, New Jersey 07058

(800) 528-3048

200811r1





MOTORS Thru-glass mount

PART NUMBER	SWEEP ANGLE
4712.R100.E0	100°
4712.R120.E0	120°
4712.R140.E0	140°
4712.R160.E0	160°

COMPATIBLE RADIAL WIPER ARMS

PART NUMBER	DESCRIPTION
202202	15" / 380mm fixed length - dry
202203	16" / 400mm fixed length - dry
200740D	14" - 16" adjustable length - dry
200740W	14" - 16" adjustable length - wet
200709DS	14" - 16" adjustable length, stainless steel - dry
200709WS	14" - 16" adjustable length, stainless steel - wet

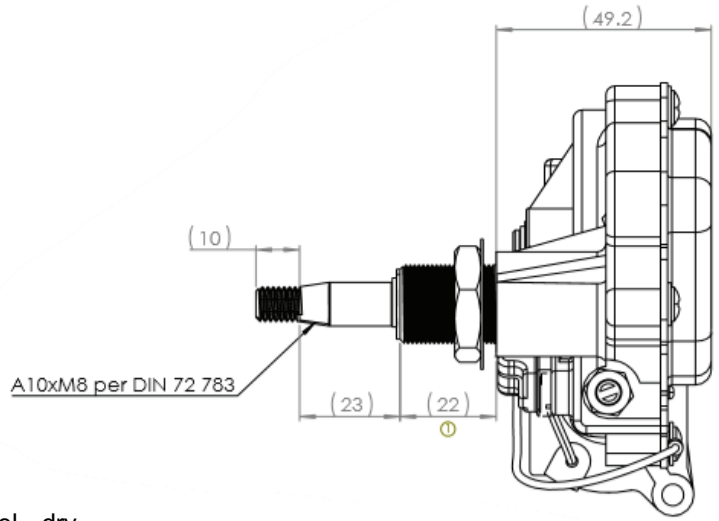

COMPATIBLE WIPER BLADES

LENGTH	STANDARD P/N	MARINE P/N	WINTER P/N	BEAM / FLEX P/N
9" / 200mm	N/A	0166509SSM	N/A	N/A
10" / 250mm	N/A	0166510SSM	N/A	N/A
11" / 275mm	066511	0166511SSM	N/A	N/A
12" / 300mm	066512	0166512SSM	N/A	N/A
13" / 330mm	066513	0166513SSM	0164713	N/A
14" / 350mm	066514	0166514SSM	N/A	N/A
15" / 380mm	066515	0166515SSM	0164715	0616815
16" / 400mm	066516	0166516SSM	0164716	0168716

COVERS

PART NUMBER	DESCRIPTION
BK16220001	white with base
BK16220002	white with base & switch knockout
BK16220011	white, no base
BK16220012	white with switch knockout, no base
BK16220003	black with base
BK16220004	black with base & switch knockout
BK16220013	black, no base
BK16220014	black with switch knockout, no base

MOUNTING KITS

PART NUMBER	DESCRIPTION
HK11808006	glass mount - 1/4"
HK11808005	panel mount - 7mm

www.wexcoind.com
customerservice@wexcoind.com

WEXCO Industries
3 Barnet Road
Pine Brook, New Jersey 07058

(800) 528-3048

200811r1

